

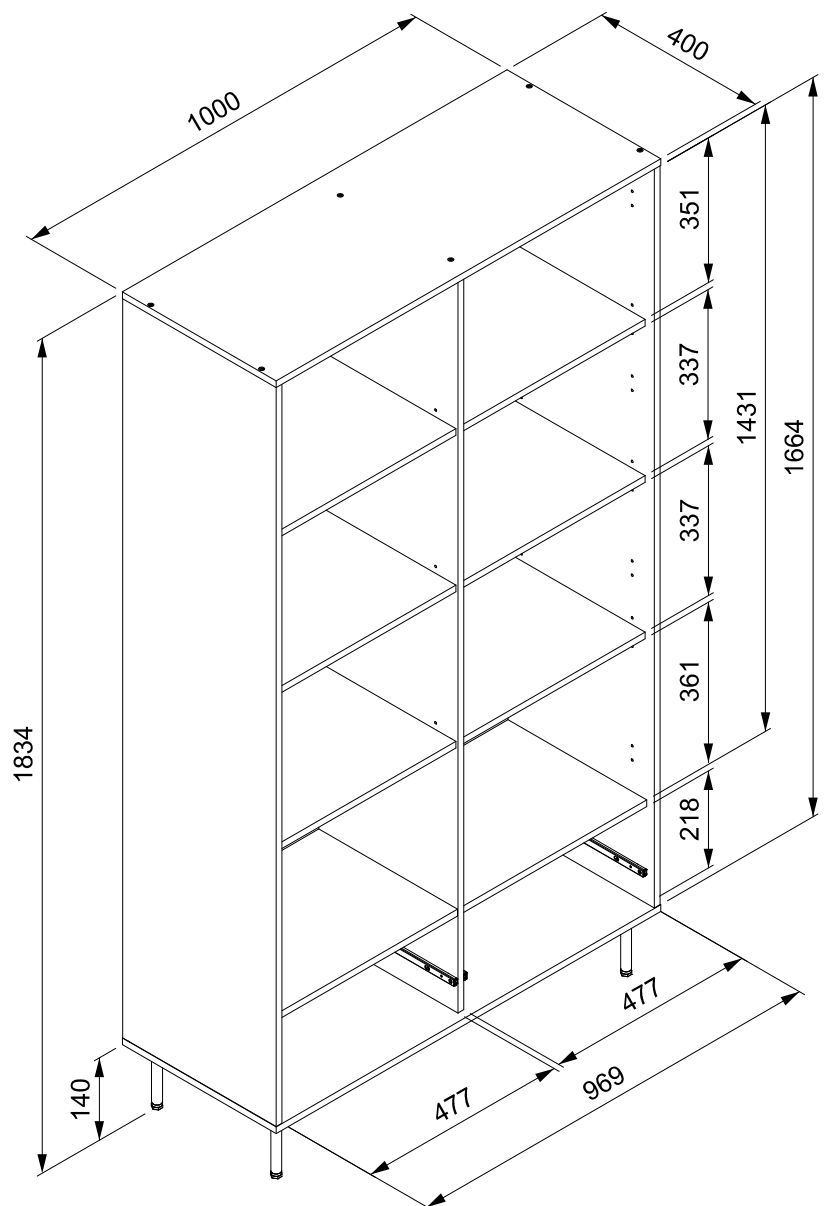

CAS52A/137

finori GmbH
Straßacker 2
D - 96253 Untersiemau

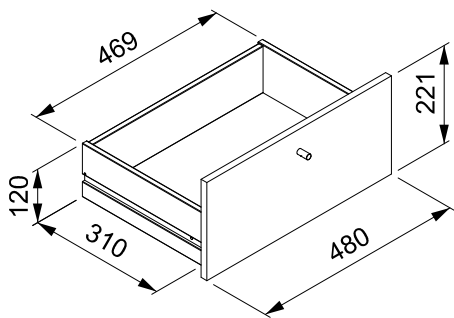

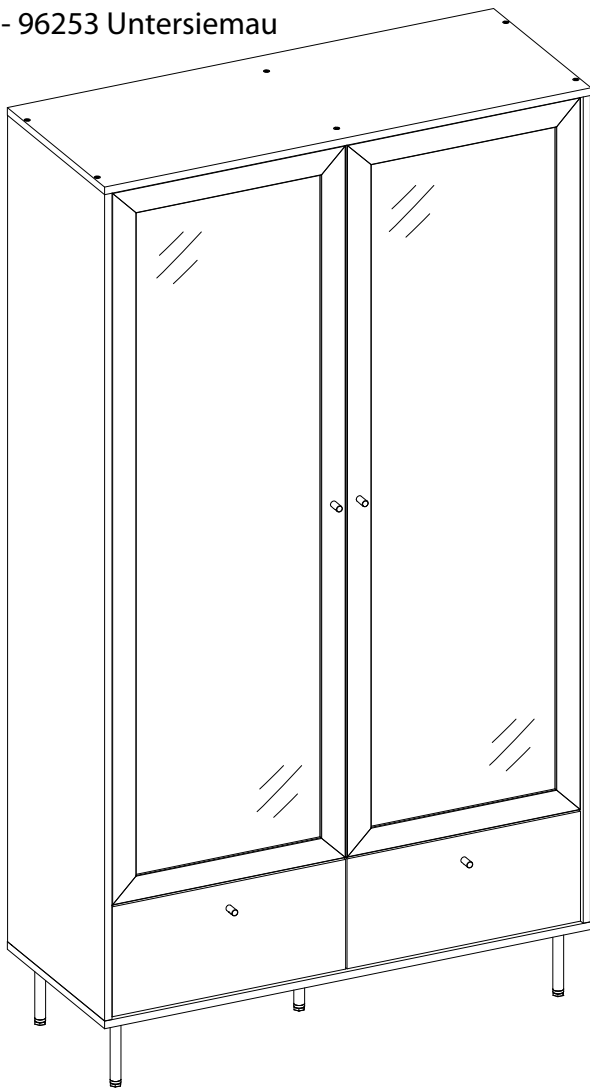

- ⓓ Befolgen Sie stets die Anleitung des Herstellers!
- Ⓞ Please generally follow the manufacturer's instructions!
- Ⓡ Suivez toujours les instructions du fabricant!
- Ⓝ Volg steeds de handleiding van de producent!
- Ⓢ Siga siempre las instrucciones del fabricante!
- Ⓡ Stale przestrzegaj instrukcji producenta!

- Ⓡ Всегда следуйте инструкции производителя!
- Ⓡ Seguire sempre le istruzioni del produttore!
- Ⓡ Mindig tartsa be a gyártó utasításait!
- Ⓡ Siga sempre as instruções do fabricante!
- Ⓡ Vždy dodržujte pokyny výrobce!



- ⓓ Verwenden Sie zur Reinigung nur ein feuchtes Tuch!
- Ⓞ Please only clean with a damp cloth!
- Ⓡ N'utilisez qu'un chiffon humide pour le nettoyage!
- Ⓝ Gebruik voor de reiniging enkel een vochtige doek!
- Ⓢ Para limpiar utilice sólo un paño húmedo!
- Ⓡ Do czyszczenia używaj wilgotnej szmatki!

- Ⓡ Для очистки используйте только влажную ткань!
- Ⓡ Per la pulizia, utilizzare solo un panno umido!
- Ⓡ A tisztításhoz elegendő egy nedves kendő használat!
- Ⓡ Para a limpeza use apenas um pano húmido!
- Ⓡ Pro čištění používejte pouze vlhký hadřík!

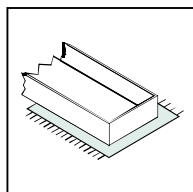

- ⓓ Bauen Sie das Produkt auf einer Unterlage auf!
- Ⓞ Please mount the product on a bottom support!
- Ⓡ Montez le produit sur une base!
- Ⓝ Monteer het product op een basis!
- Ⓢ Monte el producto sobre una base!
- Ⓡ Rozkładaj produkt na podkładce!

- Ⓡ Собирайте изделие на подстилке!
- Ⓡ Montare il prodotto su un supporto!
- Ⓡ Az összeszereléskor helyezzen a termék alá megfelelő alátétet!
- Ⓡ Monte o produto numa superfície plana!
- Ⓡ Výrobek smontujte na pevném podkladu!

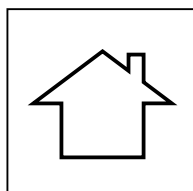

- ⓓ Verwenden Sie das Produkt nur in Innenräumen!
- Ⓞ Please exclusively use the product indoors!
- Ⓡ N'utilisez le produit qu'à l'intérieur!
- Ⓝ Gebruik het product enkel binnenshuis!
- Ⓢ Utilice el producto sólo en interiores!
- Ⓡ Używaj produkt tylko w pomieszczeniach wewnętrznych!

- Ⓡ Используйте изделие только во внутренних помещениях!
- Ⓡ Utilizzare il prodotto solo in ambienti interni!
- Ⓡ A termék csak bel terekben használható!
- Ⓡ Use o produto apenas no interior!
- Ⓡ Používejte výrobek pouze uvnitř!

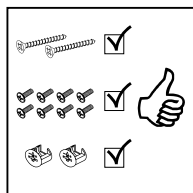

- ⓓ Legen Sie die Beschläge zusammen und prüfen Sie die Vollständigkeit!
- Ⓞ Please join the fittings and verify their completeness!
- Ⓡ Pliez les raccords ensemble et vérifiez qu'ils sont complets!
- Ⓝ Leg de onderdelen samen en controleer de volledigheid!
- Ⓢ Junte los accesorios y compruebe que están todos!
- Ⓡ Rozłóż poszczególne części i sprawdź kompletność!

- Ⓡ Положите фурнитуру в одно место и проверьте комплектность!
- Ⓡ Mettere insieme le guarnizioni e verificarne la completezza!
- Ⓡ Állítsa össze a sarokvasakat, és ellenőrizze, hogy épek-e!
- Ⓡ Coloque os encaixes juntos e verifique se estão completos!
- Ⓡ Složte armatury a zkontrolujte úplnost!

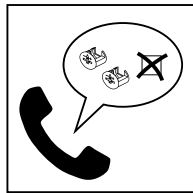

- ⓓ Bei fehlenden Teilen kontaktieren Sie den Hersteller!
- Ⓞ If parts are missing, please turn to the manufacturer!
- Ⓡ En cas de pièces manquantes, veuillez contacter le fabricant!
- Ⓝ Contacteer de fabrikant als er onderdelen ontbreken!
- Ⓢ En el caso de que falten piezas, póngase en contacto con el fabricante!
- Ⓡ W razie braku części skontaktuj się z producentem!

- Ⓡ При отсутствии каких-либо частей обратитесь к производителю!
- Ⓡ In caso di pezzi mancanti, contattare il produttore!
- Ⓡ Ha hiányozna valamelyik elem, lépjen kapcsolatba a gyártóval!
- Ⓡ Em caso de peças em falta, entre em contato com o fabricante!
- Ⓡ Pro chybějící díly kontaktujte výrobce!

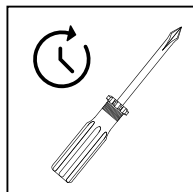

- ⓓ Ziehen Sie die Schrauben nach einiger Zeit des Gebrauchs erneut fest!
- Ⓞ Please re-tighten the screws after having used the product for a while!
- Ⓡ Resserrer les vis après un certain temps d'utilisation!
- Ⓝ Draai de schroeven na een zekere gebruikstijd opnieuw vast!
- Ⓢ Asegure de nuevo los tornillos tras usarlo durante un tiempo!
- Ⓡ Po pewnym czasie użytkowania ponownie dokręć śruby!

- Ⓡ Спустя некоторое время использования подкрутите гайки!
- Ⓡ Stringere nuovamente le viti dopo un certo periodo di utilizzo!
- Ⓡ A használat során némi idő elteltével húzza meg újra a csavarokat!
- Ⓡ Reaperte os parafusos após algum tempo de uso!
- Ⓡ Po určité době používání šrouby znovu utáhněte!



CAS52A/137

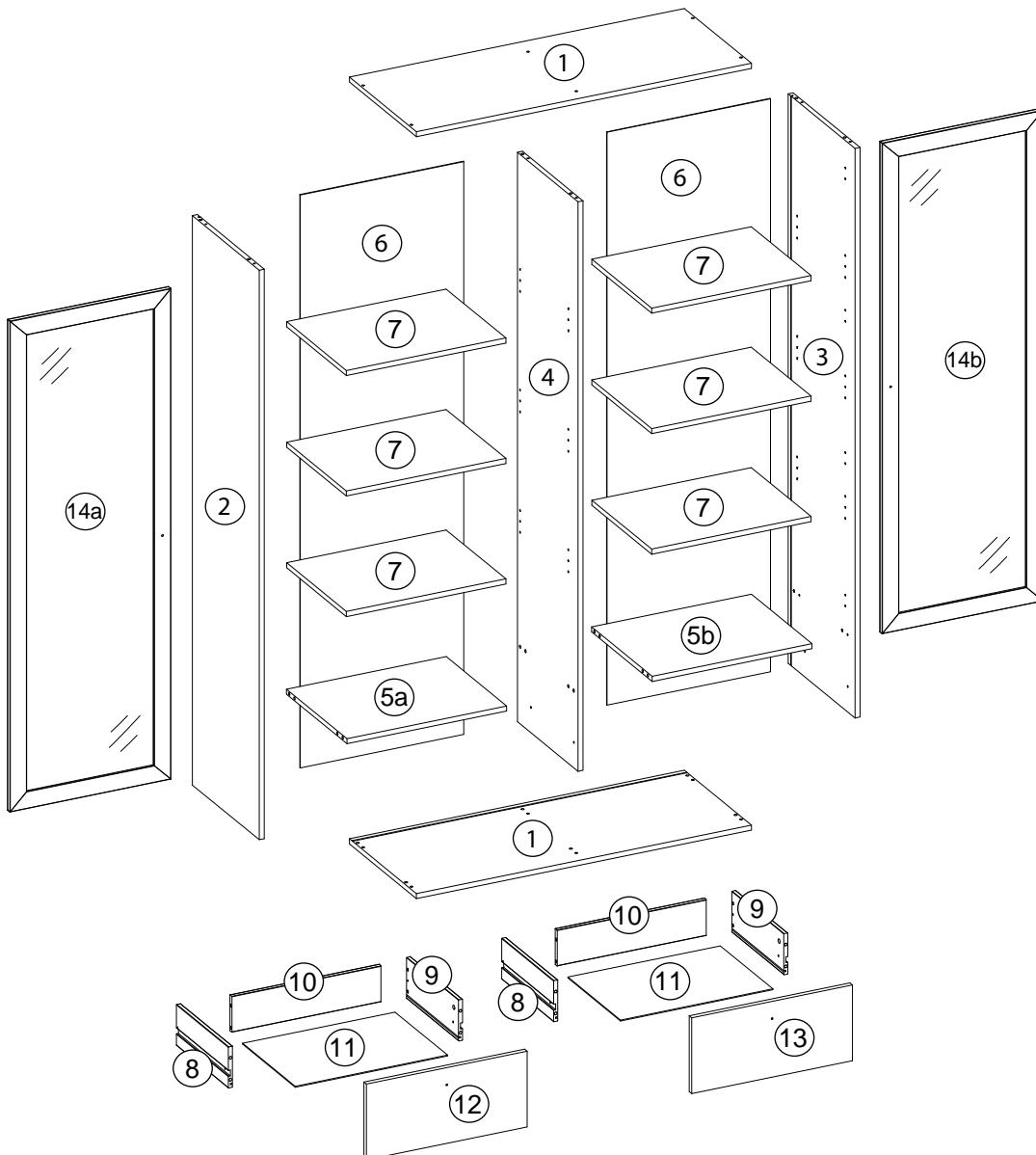
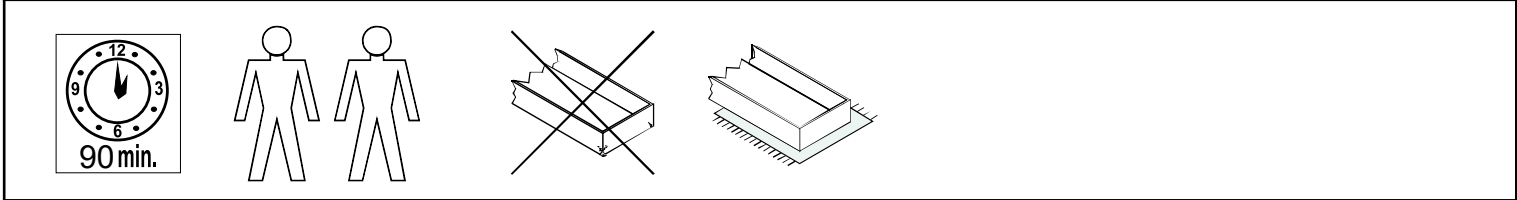

Dimensions / Abmessung in mm/		
①	2 x	1000 x 400 x 15
②	1 x	1664 x 399 x 15
③	1 x	1664 x 399 x 15
④	1 x	1664 x 362 x 15
⑤a	1 x	477 x 361 x 15
⑤b	1 x	477 x 361 x 15
⑥	2 x	1674 x 488 x 3
⑦	6 x	476 x 357 x 15
⑧	2 x	310 x 120 x 12
⑨	2 x	310 x 120 x 12
⑩	2 x	445 x 105 x 12
⑪	2 x	455 x 314 x 2,5
⑫	1 x	480 x 221 x 15
⑬	1 x	480 x 221 x 15
⑭a	1 x	1434 x 480 x 15
⑭b	1 x	1434 x 480 x 15

BOX 1	2, 3, 4
BOX 2	6, 12, 13, 14a, 14b
BOX 3	1, 5a, 5b, 7, 8, 9, 10, 11

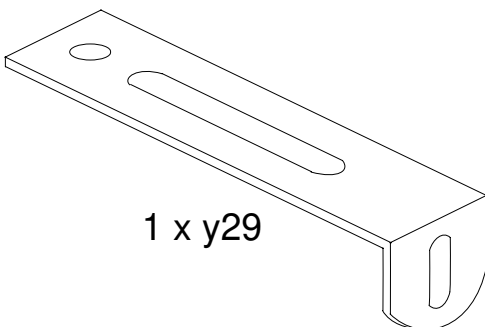
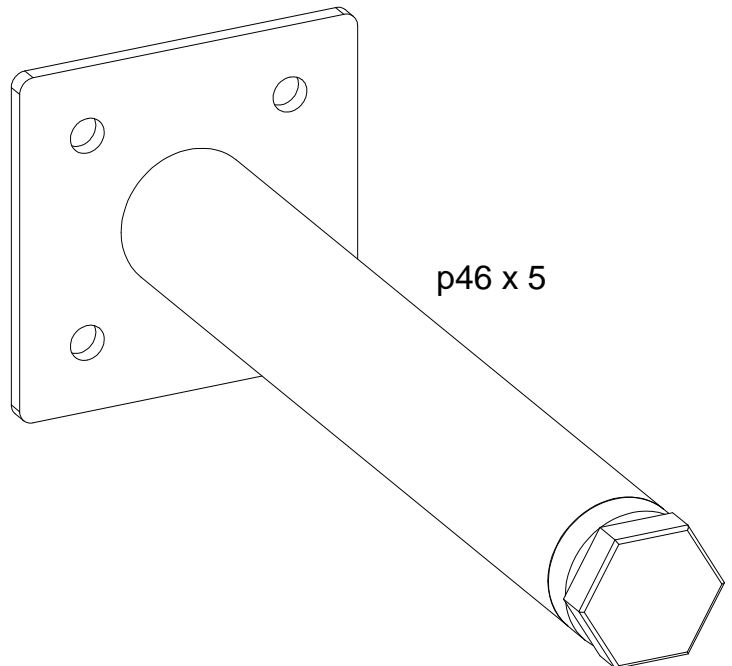
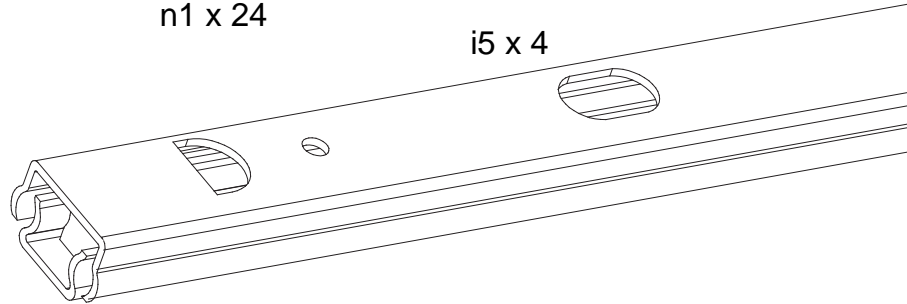
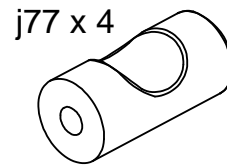
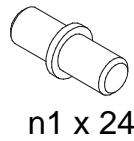
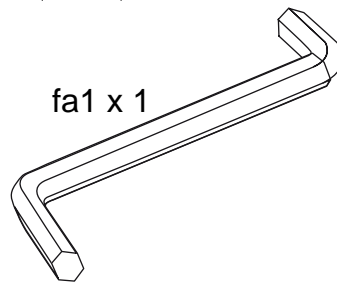
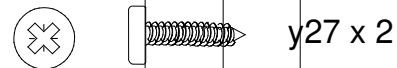
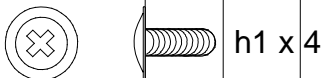
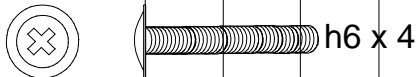
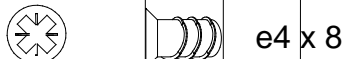
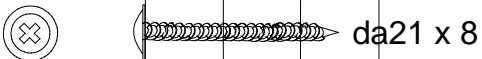
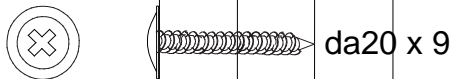
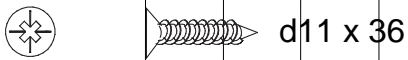
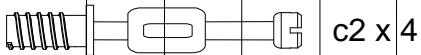
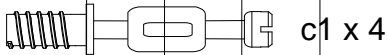
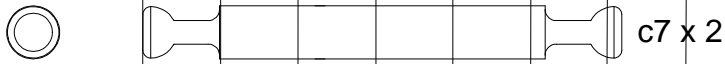
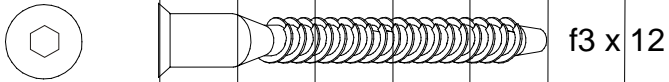

BOX 1	
BOX 2	
BOX 3	✓

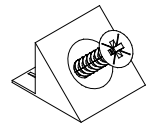
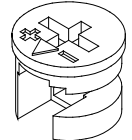

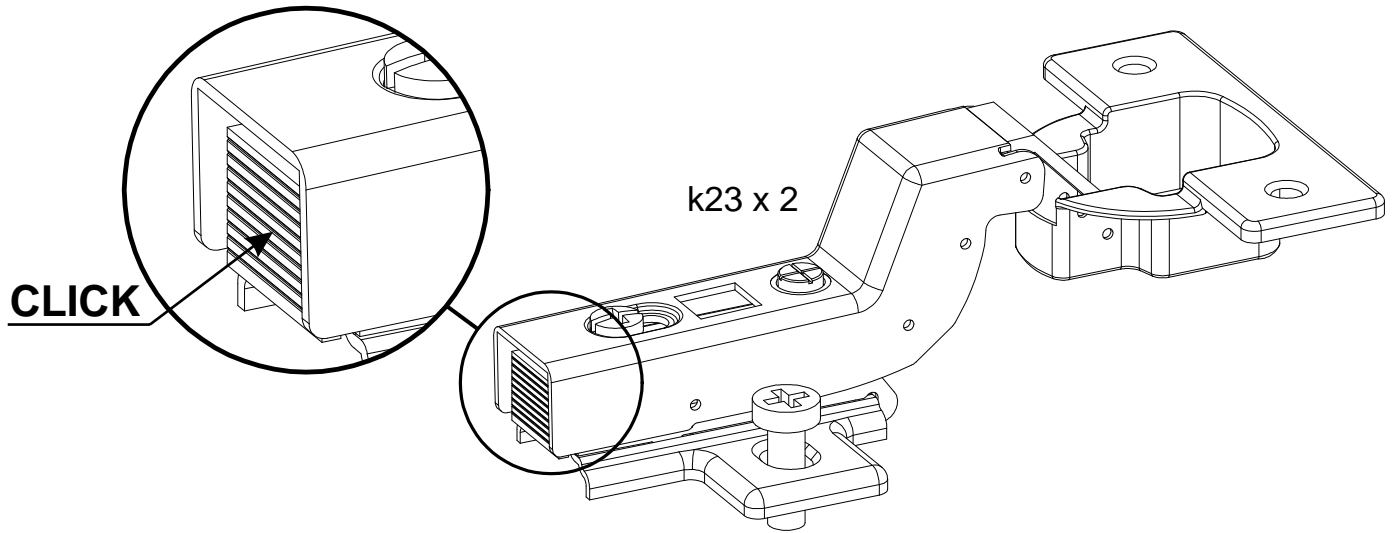
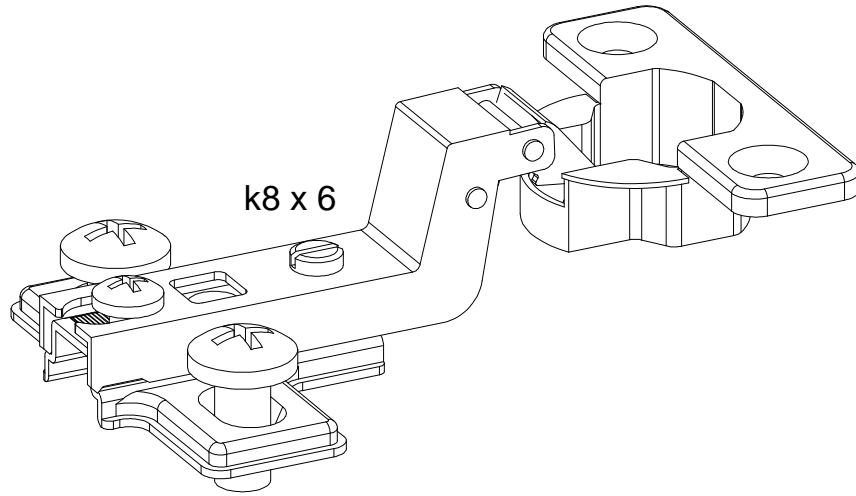

A

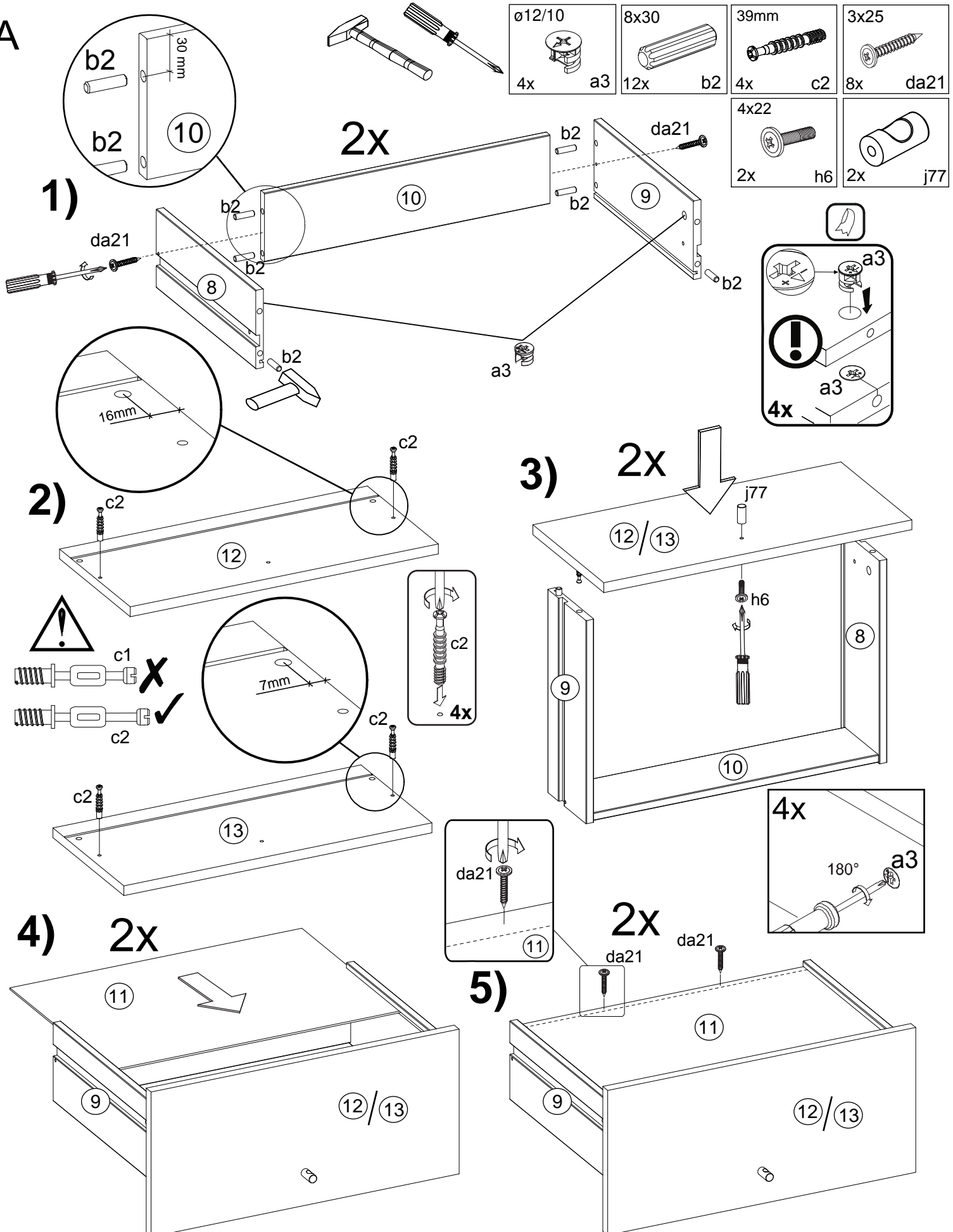



CAS52A/137

B

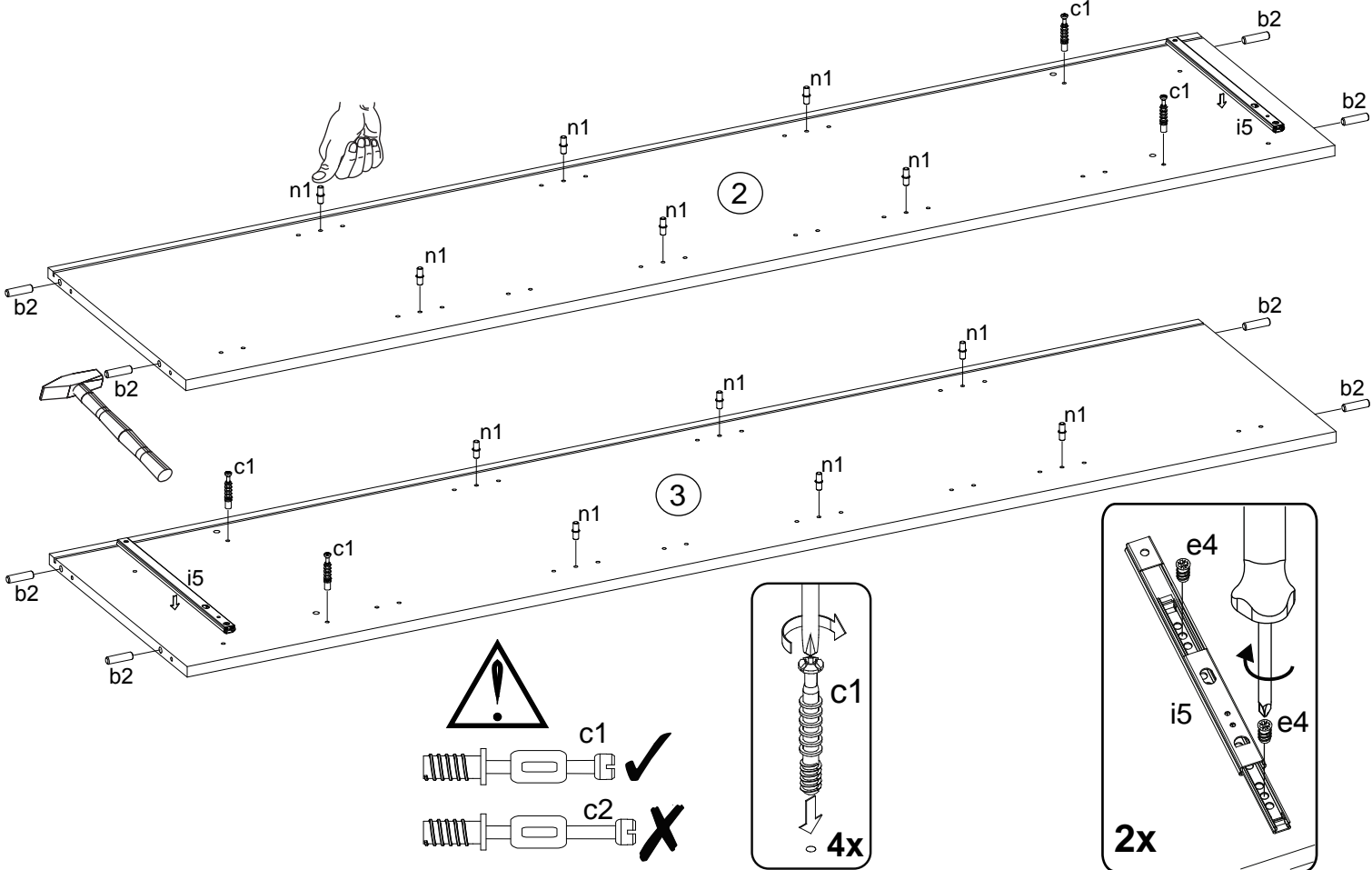
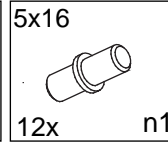
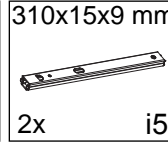
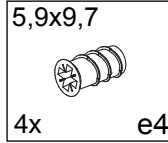
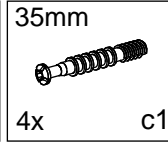
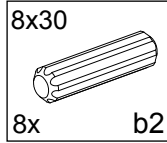
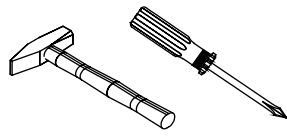

C

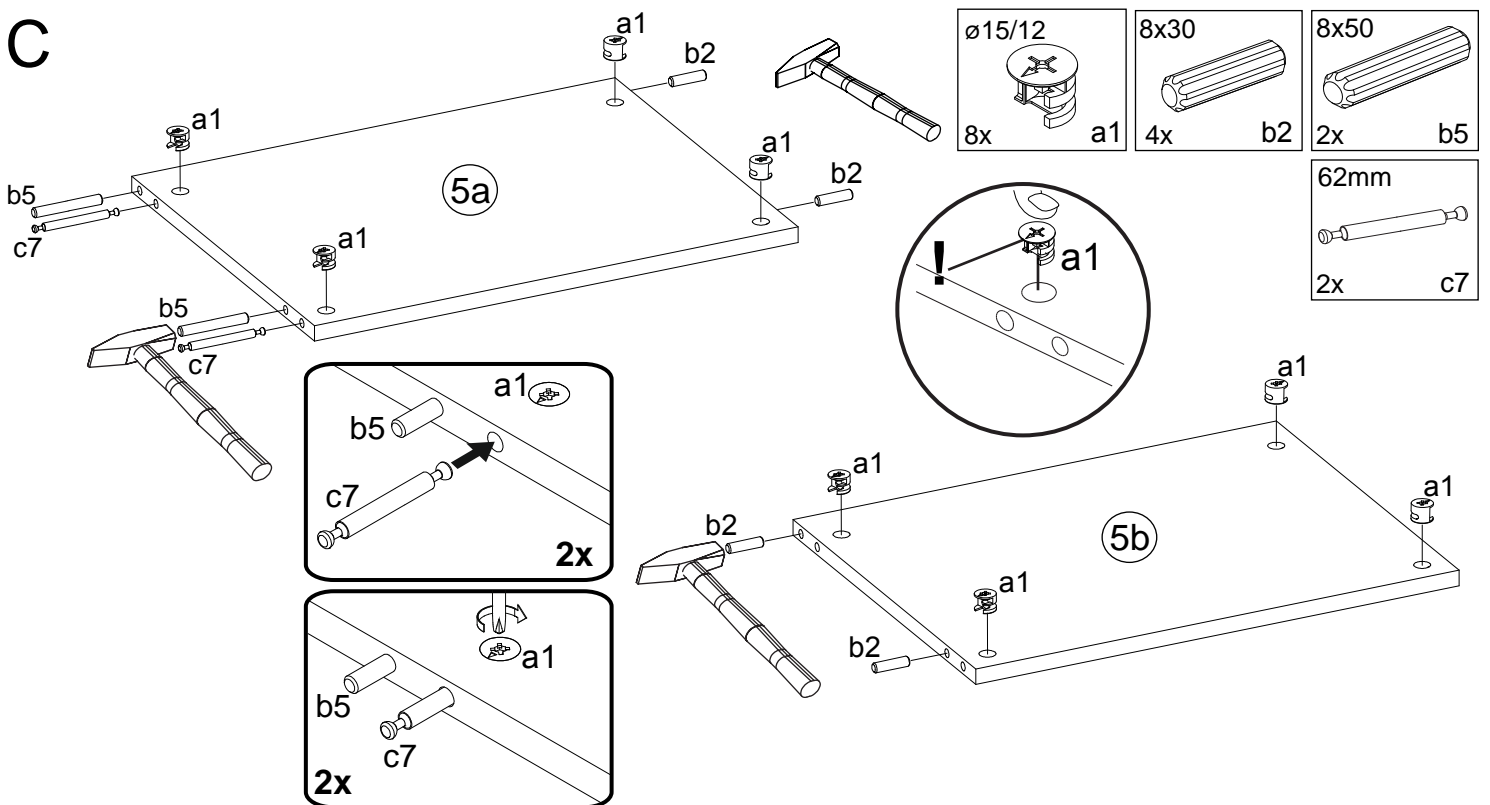



CAS52A/137

D

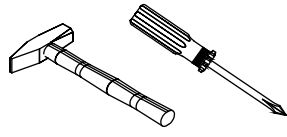

8x30 4x b2	5,9x9,7 4x e4	310x15x9 mm 2x i5	5x16 12x n1
------------------	---------------------	-------------------------	-------------------

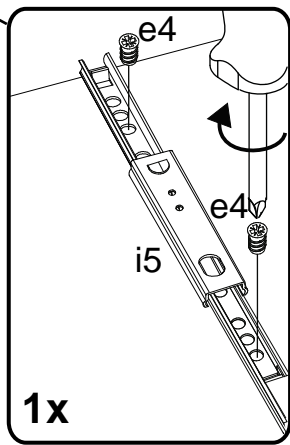
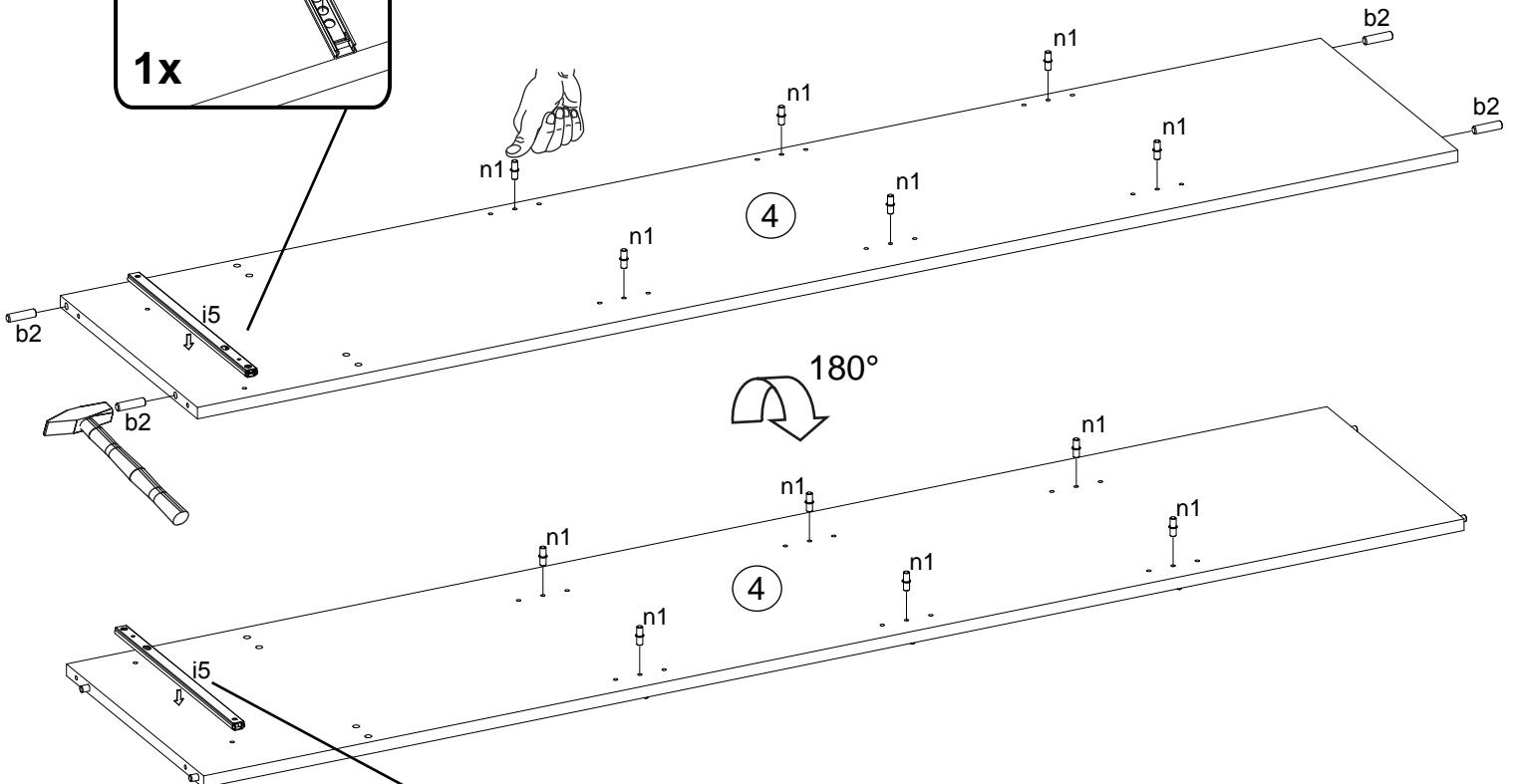
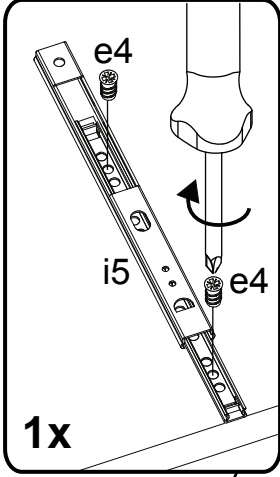



CAS52A/137

E

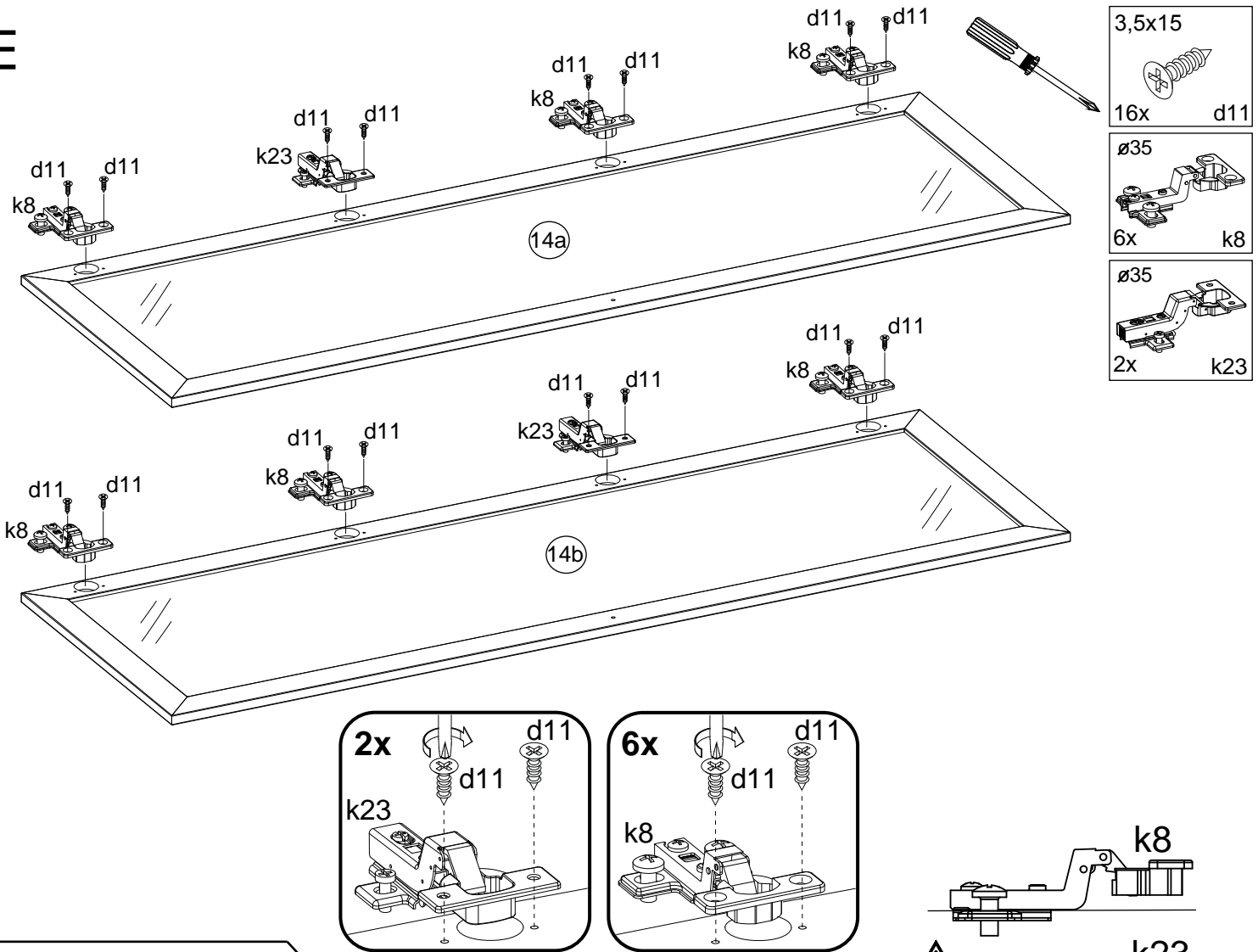

F

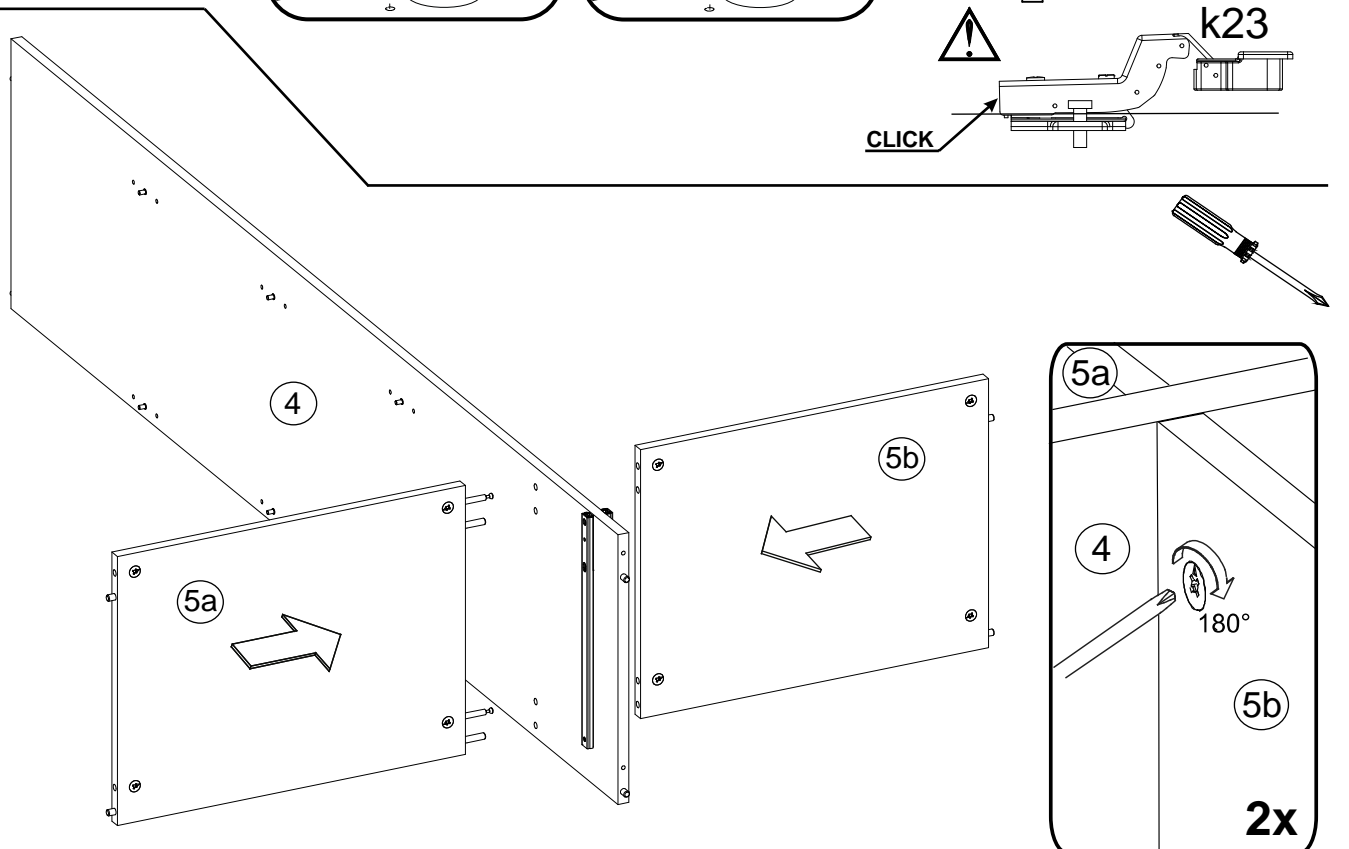

G

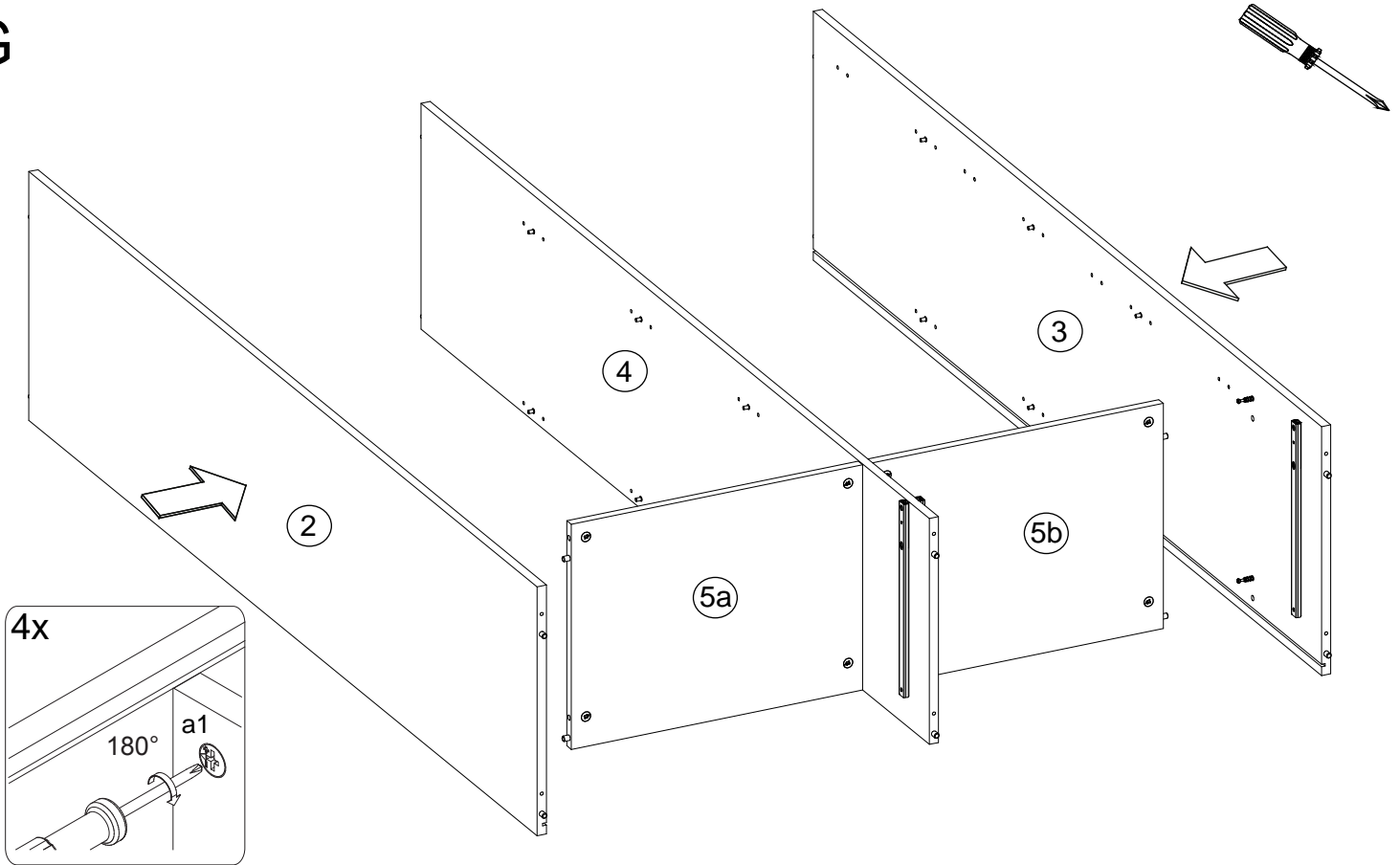

H

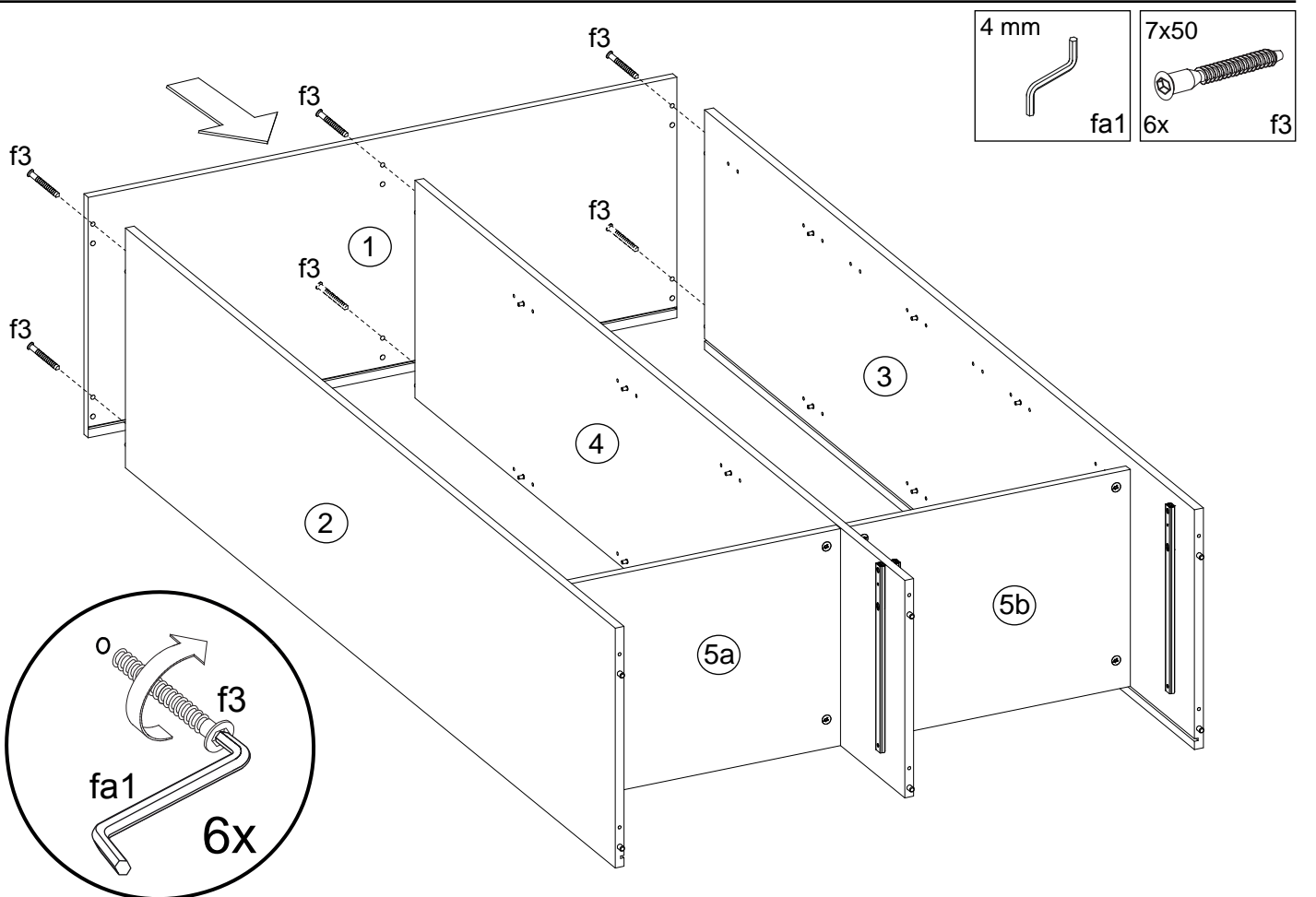

I

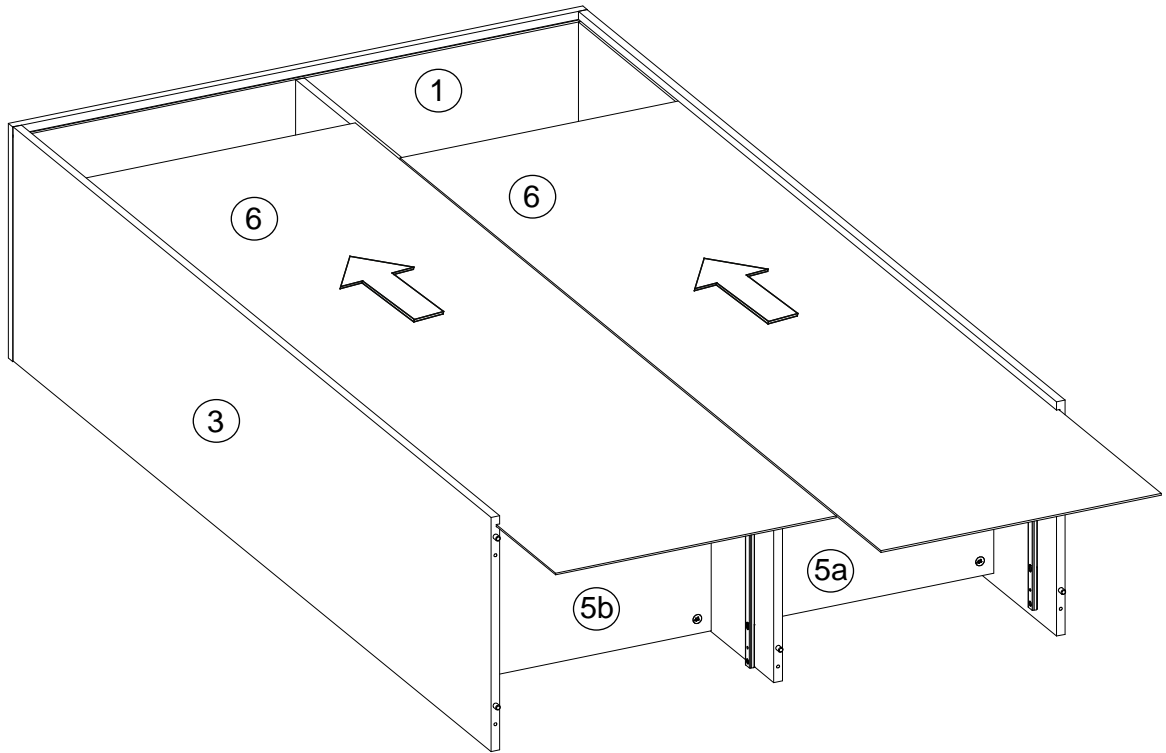

J

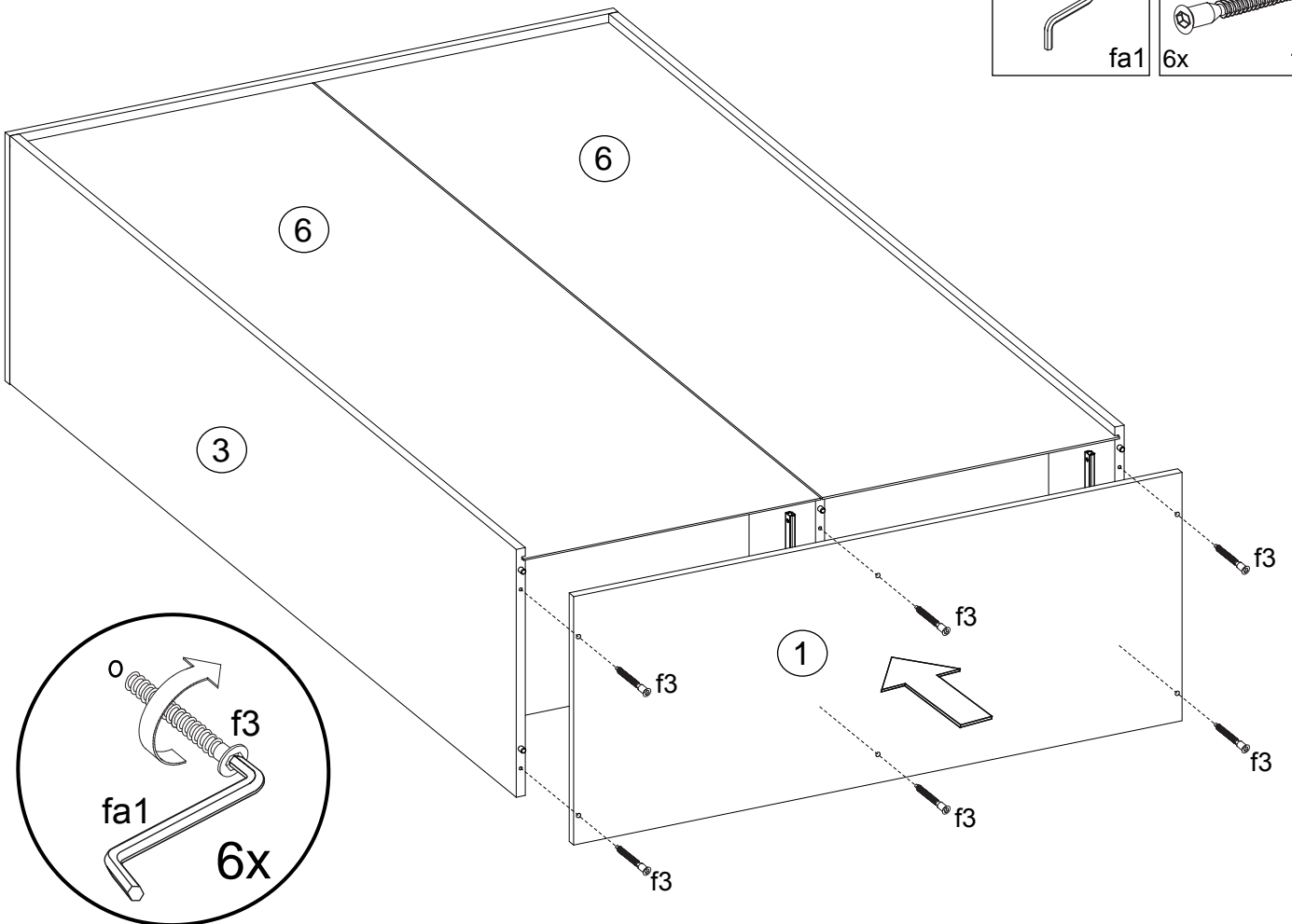
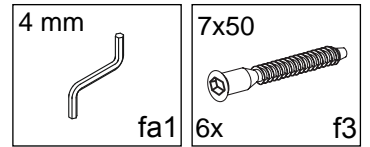

K

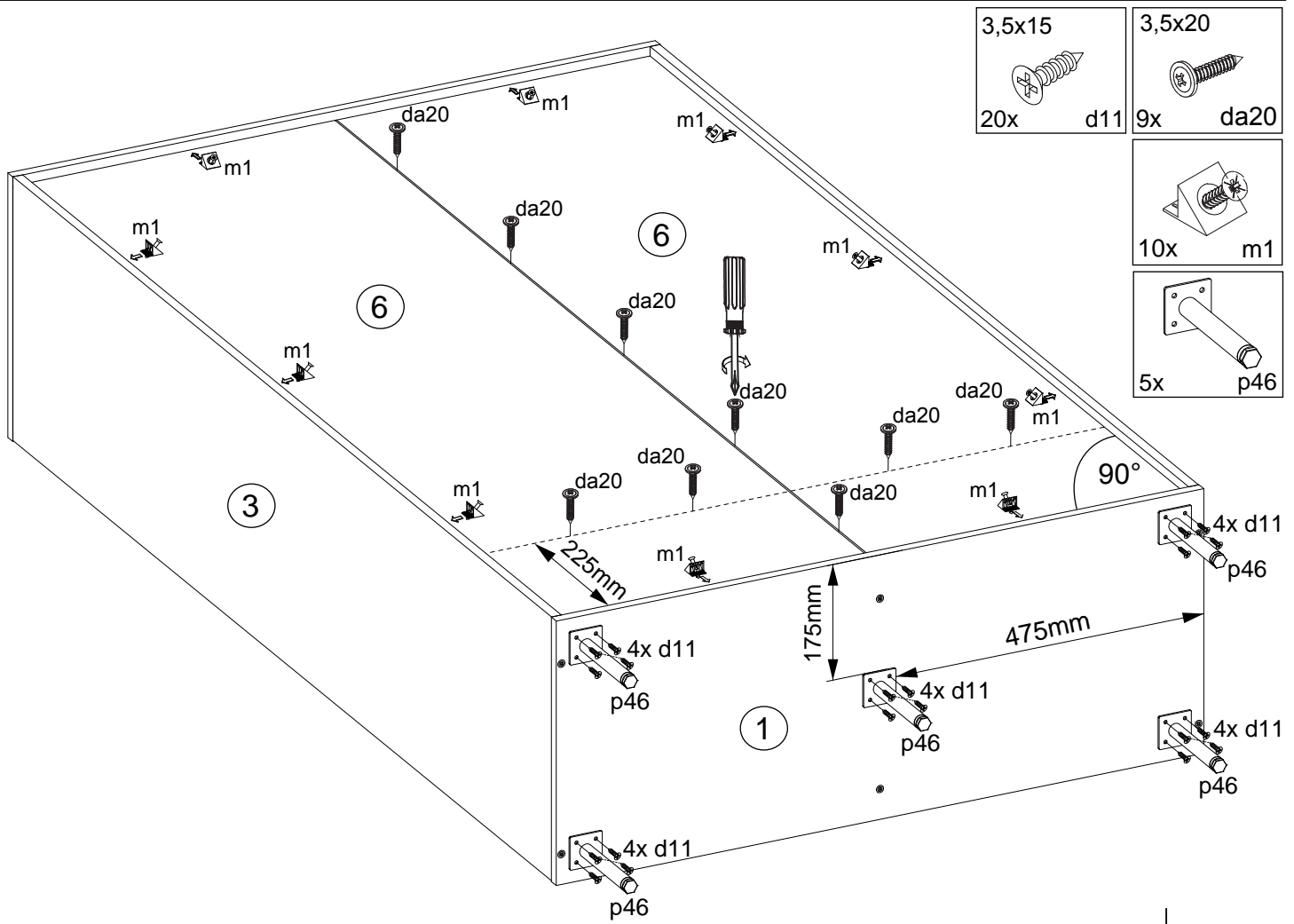

- | | | | |
|---------------|-----|--------------|------|
| 3,5x15
20x | d11 | 3,5x20
9x | da20 |
| | | | |
| | | | |
| 10x | | m1 | |
| | | | |
| 5x | | p46 | |

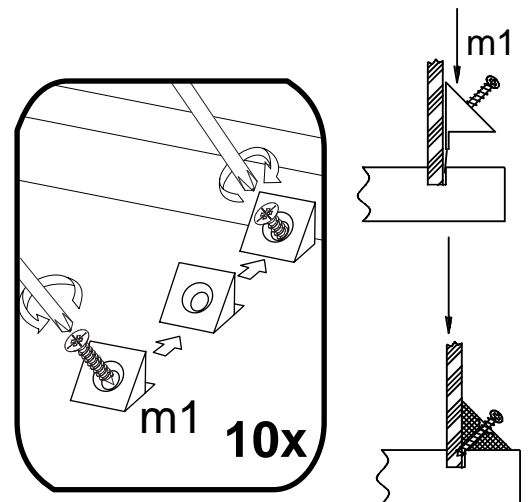
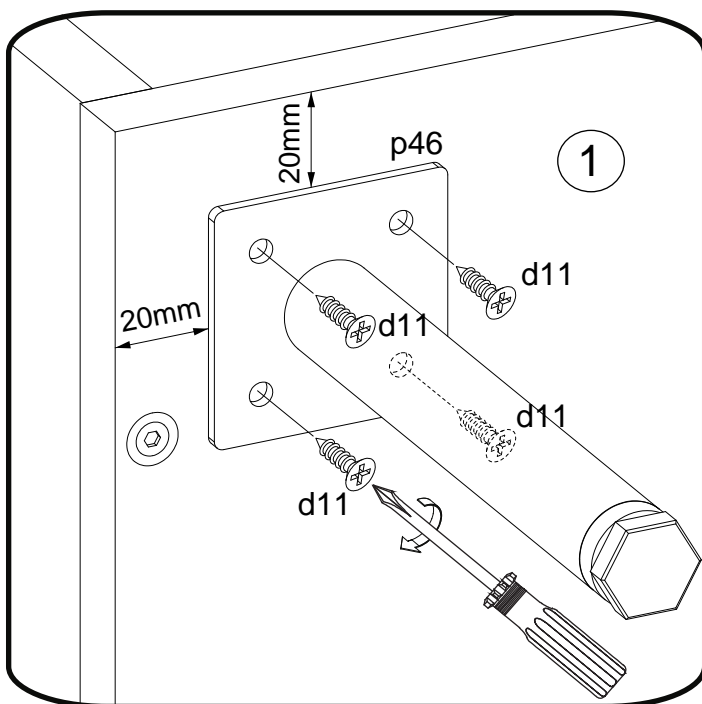

L

Le meuble doit être fixé au mur!
 Das Möbel muss an der Wand befestigt werden!
 This unit must be secured to a wall using suitable fixing (not supplied)!

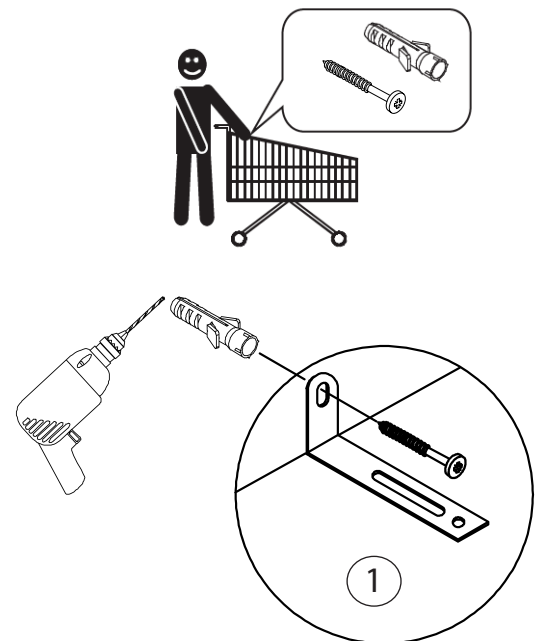
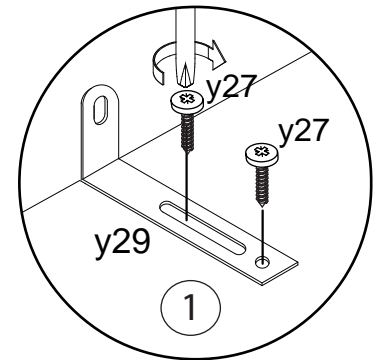
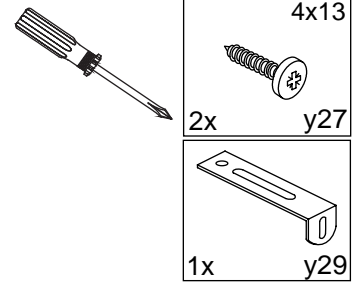
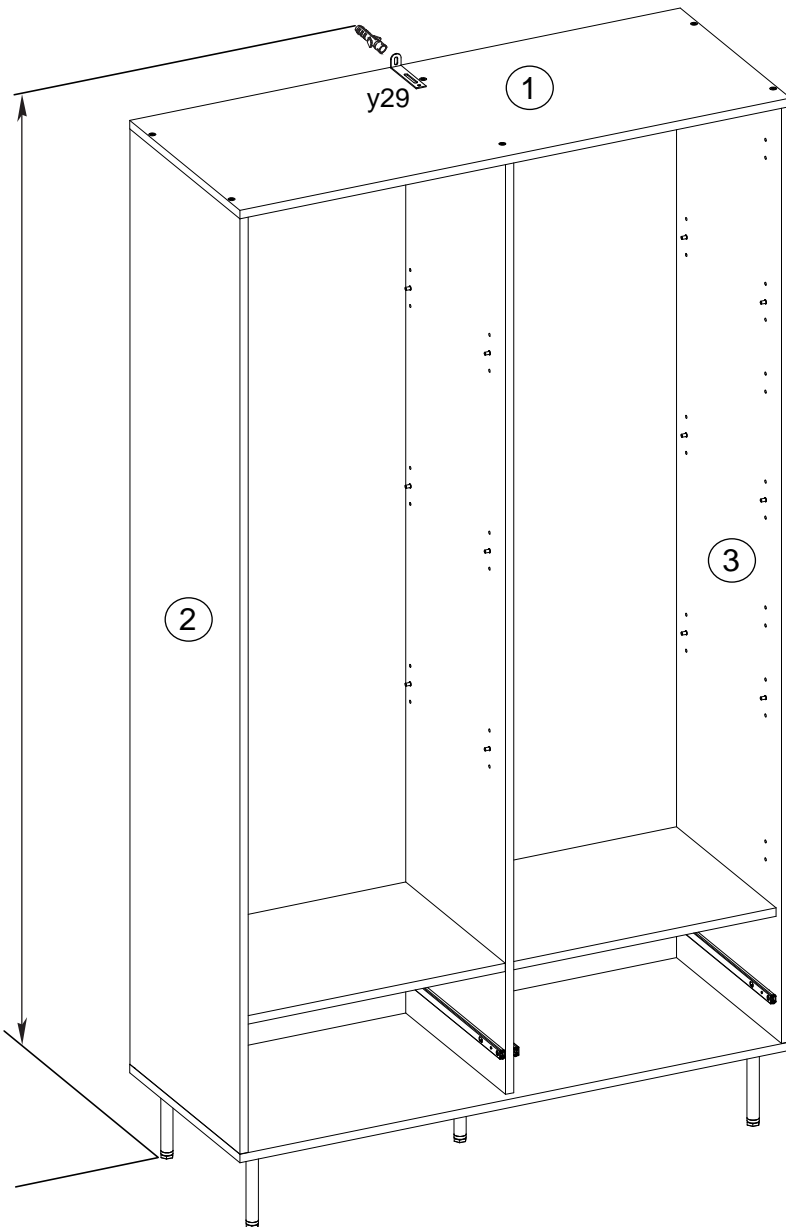

***Attention!**
 Veuillez-vous informer sur le type de cheville et vis approprié à la nature de votre mur.

***Achtung!**
 Informieren Sie sich vor der Wandmontage über das geeignete Montagmaterial für Ihre Wand!

***Caution!**
 Please inform yourself about mounting material suitable for your wall before mounting.

M

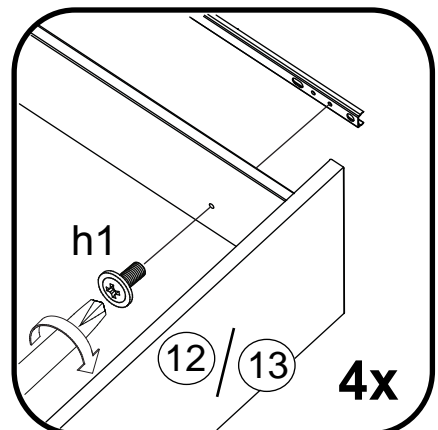
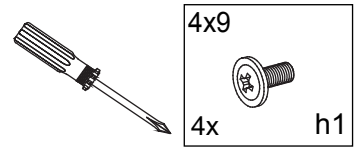
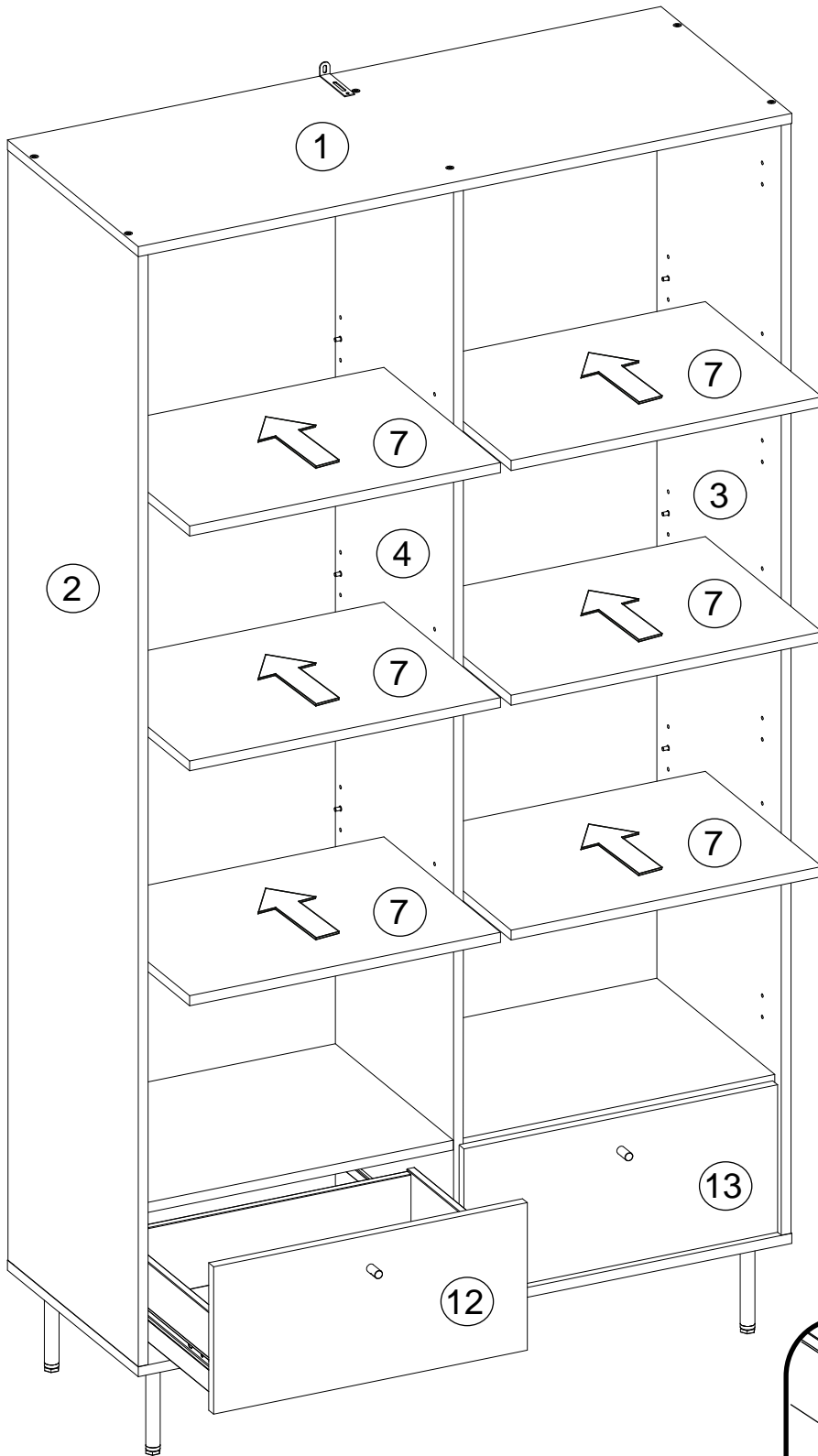

N

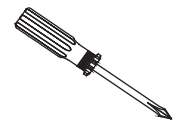
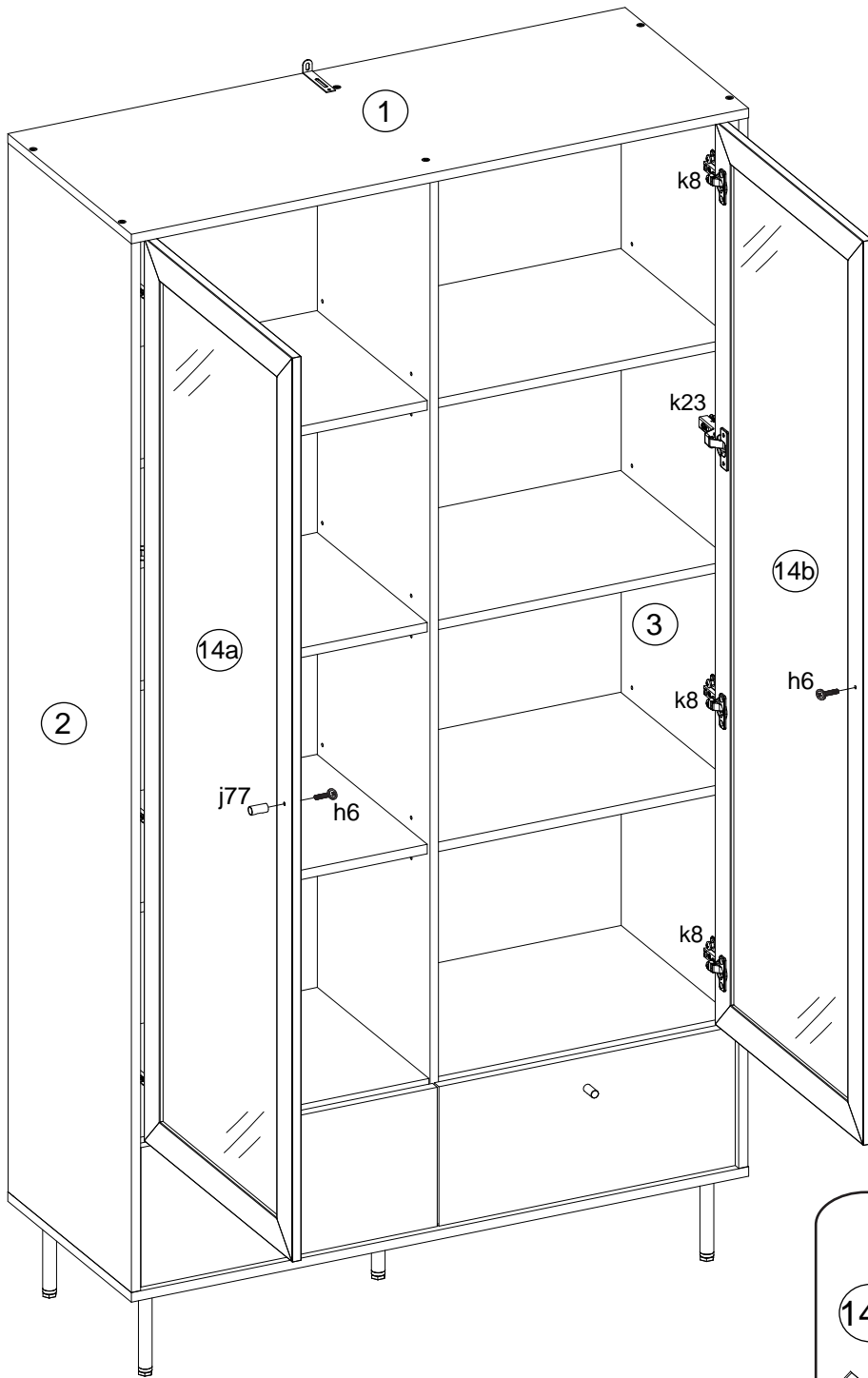

4x22
2x h6

2x j77

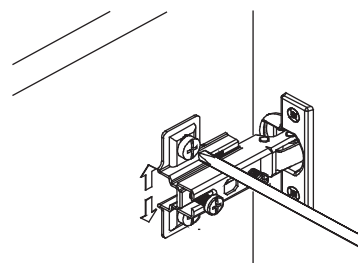
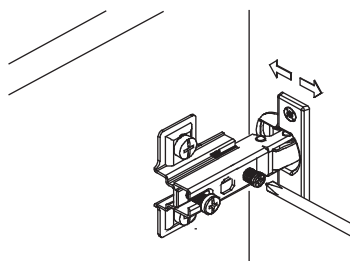
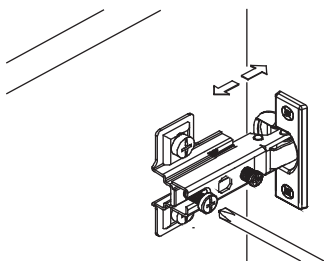
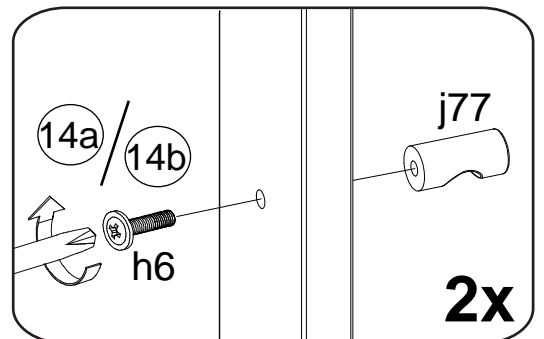
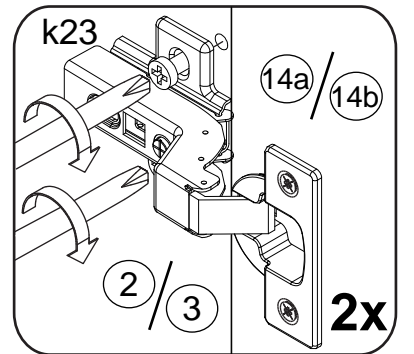
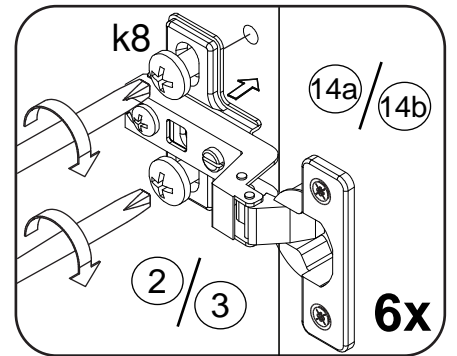



- Ⓓ Das Möbel muss an der Wand befestigt werden!
- Ⓔ Please ensure to mount the furniture to the wall!
- Ⓕ Les meubles doivent être fixés au mur!
- Ⓝ Het meubel moet aan de wand worden vastgemaakt!
- Ⓔ El mueble se tiene que fijar a la pared!
- Ⓜ Mebel należy przymocować do ściany!



- Ⓓ Informieren Sie sich vor der Wandmontage über das geeignete Montagematerial!
- Ⓔ Please get informed on suitable assembly materials before commencing the wall-mounting!
- Ⓕ Renseignez-vous sur le matériel de montage approprié avant le montage mural!
- Ⓝ Informeer u voor de wandmontage over het geschikte montagematerieel!
- Ⓔ Infórmese antes del montaje en la pared del material apropiado de montaje!
- Ⓜ Przed montażem na ścianie upewnij się, jaki jest potrzebny właściwy materiał montażowy!



- Ⓓ Beschaffen Sie sich das angemessene Material zur Wandbefestigung!
- Ⓔ Please obtain suitable wall-mounting materials!
- Ⓕ Procurez-vous le matériel approprié pour le montage mural!
- Ⓝ Verschaf u het adequate materieel voor de wandbevestiging!
- Ⓔ Procúrese el material adecuado para la fijación a la pared!
- Ⓜ Zakup odpowiedni materiał do przymocowania na ścianie!



- Ⓓ Lassen Sie die Wandbefestigung von einer fachkundigen Person vornehmen!
- Ⓔ Ensure all wall-mounting is carried out by competent personnel!
- Ⓕ Faites effectuer le montage mural par une personne compétente!
- Ⓝ Laat de wandbevestiging door een professional uitvoeren!
- Ⓔ Deje que la fijación a la pared la haga un profesional!
- Ⓜ Zlec przymocowanie do ściany odpowiednio doświadczonej osobie!

- Ⓜ Мебель должна крепиться к стене!
- Ⓙ Il mobile deve essere fissato alla parete!
- Ⓜ A bútor a falon rögzítendő!
- Ⓜ O móvel tem que ser fixado na parede!
- Ⓒ Nábytek musí být připevněn ke stěně!

- Ⓜ Перед тем, как крепить мебель к стене, получите информацию о подходящем крепежном материале!
- Ⓙ Prima del fissaggio alla parete, informarsi sul materiale di montaggio adatto!
- Ⓜ A falra szerelés előtt tájékozódjon, hogy ehhez milyen szerelőanyagok szükségesek!
- Ⓜ Antes da montagem na parede, informe-se sobre o material de montagem adequado!
- Ⓒ Informujte se o vhodném montážním materiálu před montáží na stěnu!

- Ⓜ Приобретите соответствующий материал для крепления к стене!
- Ⓙ Procurarsi il materiale opportuno per il fissaggio alla parete!
- Ⓜ Szerezze be a falra szereléshez szükséges, megfelelő anyagokat!
- Ⓜ Obtenha o material adequado para a montagem na parede!
- Ⓒ Opatřte si vhodný materiál pro montáž na stěnu!

- Ⓜ Поручите выполнение работ по креплению к стене специалисту!
- Ⓙ Far effettuare il fissaggio alla parete ad un esperto!
- Ⓜ A bútor falra rögzítését végeztesse ehhez értő személlyel!
- Ⓜ A montagem na parede deve ser executada por uma pessoa competente!
- Ⓒ Montáž na stěnu nechte provést odborně způsobilou osobou!

